

180-102 (07 Receptacle) Fiber Optic Probe Adapter

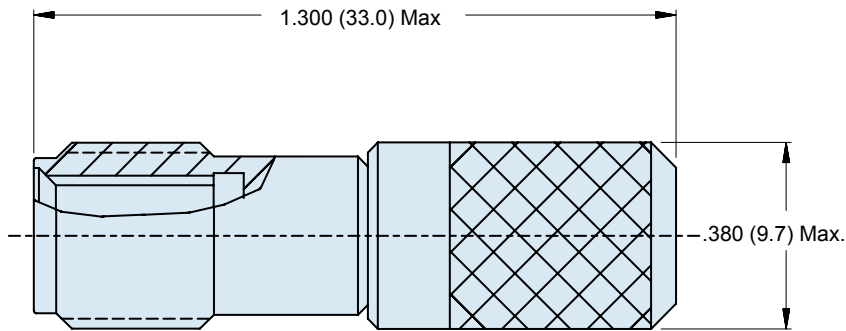
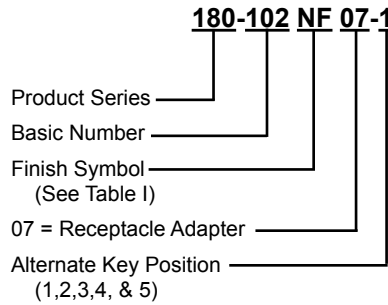

RECEPTACLE ASSEMBLY-07

APPLICATION NOTES

1. Assembly identified with manufacturer's name and P/N, space permitting.
2. For Fiber Optic Test Probe Terminus See Glenair drawing 181-006.
3. Material/ Finish:
 Shell/ Plug- Al Alloy/ See Table I
 Rear Body- Al Alloy/ See Table I
 Coupling Nut- Al Alloy/ See Table I
 Retaining Clips- Beryllium Copper/ N.A.
 Spring- Stainless Steel
 Wire Retention- Stainless Steel
 O-Ring- Fluorosilicone
4. Metric dimensions (mm) are indicated in parentheses.

TABLE I: FINISH

SYM	MATERIAL	FINISH
M	Aluminum	Electroless Nickel
NF	Aluminum	Cadmium/Olive Drab over Electroless Nickel (500-Hr. Salt Spray)
C	Aluminum	Black Anodize